

ARGUS® F240

T H E F I B E R T E S T E R

Sel. OPM

xPON-ID

Through Mode

GPON

XGS-PON

FTTH

FIT

OLS

VFL

2.5GigE

10GigE

SFP

WLAN

Data
101101011011

IP TV

Vo IP

Speed test

iperf

RFC
6349



data sheet: technical data subject to change.

intec

GESELLSCHAFT FÜR
INFORMATIONSTECHNIK mbH

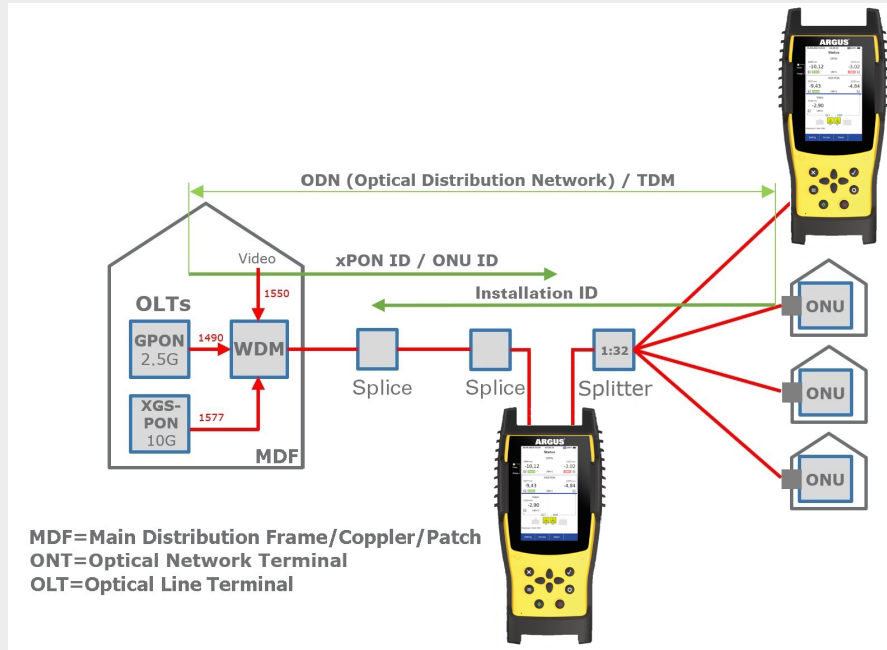

ARGUS® F240: The fiber tester

The ARGUS® F240 fiber tester scores with improved performance when testing on mixed fiber optic connections. The high-quality tester is well equipped for the expansion of future networks.

Modern design and new housing concept

With its robust and compact design, the ARGUS® F240 is ideally suited for the demands of daily field use. It is operated primarily via touchscreen, with familiar ARGUS® menu structure.

Tests on mixed optical fiber accesses

The ARGUS® F240 reliably tests on GPON and XGS-PON interfaces in the quality you have come to expect. The selective 5-fold power meter can be switched into an existing PON connection in through mode, allowing the optical levels on the different downstream (OLT) and upstream (ONT) wavelengths for GPON, XGS-PON and a video overlay to be accurately determined simultaneously via five separate filters. In this process, other transmitters that may be on the line (so-called alien ONT) can be detected. In addition, the PON ID can be read out from the PLOAM message. On GPON as on XGS-PON, the ARGUS® can also perform a complete ONT simulation with IP and performance tests at up to 10 Gbit/s.

Additional features

The ARGUS® F240 also has many other test functions, such as WLAN analyzer, triple play tests such as VoIP, IPTV and data tests in the form of upload/download, ping and traceroute as well as iperf or high-performance IP speed tests directly on the fiber or on Ethernet. The SFP slot can be used, among other things, for the deployment of Active Ethernet (AON), as is often the case in FTTH installations. In addition, the Fiber Inspection Tool can be connected via USB, which detects scratches and defects on optical fibers and displays them as a video image and in tabular form.

intec Gesellschaft für Informationstechnik mbH

intec Gesellschaft für Informationstechnik mbH has been successfully developing products for the international telecom markets for more than 30 years. Meanwhile specialized in highquality telecommunication measuring devices, we belong to the leading suppliers of fiber optic, G.fast, xDSL and IP measuring technology in Europe and beyond.

Our ARGUS® testers are ideal for developing and documenting new fiber optic infrastructure for the rapid expansion of modern optical networks. They simplify day-to-day work in the maintenance and testing of modern copper-based broadband interfaces as well as in the fiber-optic sector and support troubleshooting and fault location.

Our customers have appreciated the quality of our products and services for many years. This trust in our products has enabled us to supply more than 100,000 ARGUS® testers throughout the world during the last 20 years – a large majority of which have been delivered to international companies such as Deutsche Telekom, Vodafone, Telefonica, KPN or A1 Telekom Austria.

data sheet: technical data subject to change.



ARGUS® MADE IN GERMANY

Specifications Fiber Tests:

| General: Application, Settings + Results: | | | |
|---|--|--|---|
| Selective xPON-OPM for GPON / XGS-PON | <ul style="list-style-type: none"> Measuring range: <ul style="list-style-type: none"> 1577 & 1490 nm (filtered): from -40 to +6 dBm 1270 to 1625 nm (broadband): from -50 to +10 dBm Accuracy: ±0.5 dB Calibration conditions: -20 dBm, 23°C ±5 K | <ul style="list-style-type: none"> Connector: SC/APC, SFP+, LAN 10 GBase-T Readout of PON ID and XGS-PON ID* via SC/APC, detection up to: <ul style="list-style-type: none"> GPON ≥ -30 dBm XGS-PON ≥ -28 dBm <p>* The network must provide the ID for this.</p> | <ul style="list-style-type: none"> Full ONT simulation (GPON ONT or XGS-PON ONT) via additional GPON/ XGS-PON SFP transceiver module IP/Performance tests via SFP+, LAN 10/5/2.5/1 GBase-T, 100Base-Tx with up to 10 Gbit/s (opt.) |
| Selective Through Mode xPON-OPM for GPON/ XGS-PON | <ul style="list-style-type: none"> Measuring range: <ul style="list-style-type: none"> Downstream (OLT socket): <ul style="list-style-type: none"> 1577 & 1490 nm (filtered): from -40 to +7 dBm (max. power +12 dBm) 1550 nm (filtered): from -50 to +15 dBm Upstream (ONT socket): <ul style="list-style-type: none"> 1310 nm (filtered): from -50 to +10 dBm 1270 nm (filtered): from -50 to +10 dBm Accuracy: filtered ±0.5 dB | <ul style="list-style-type: none"> Insertion loss: 1.5 dB Alien ONT detection (burst + permanent) Calibration conditions: -20 dBm, 23°C ±5 K Connector: 2x SC/APC (ONT + OLT), SFP+, LAN 10 GBase-T Full ONT simulation (GPON ONT or XGS-PON ONT) via additional GPON/ XGS-PON SFP transceiver module | <ul style="list-style-type: none"> Readout of PON ID and XGS-PON ID* via SC/APC, detection up to: <ul style="list-style-type: none"> GPON ≥ -30 dBm XGS-PON ≥ -28 dBm IP/Performance tests via SFP+, LAN 10/5/2.5/1 GBase-T, 100Base-Tx with up to 10 Gbit/s (opt.) <p>* The network must provide the ID for this.</p> |
| GPON Tester | GPON Modem Simulation, ONT, CPE ITU-T G.984 via GPON Transceiver <ul style="list-style-type: none"> GigaBit Passive Optical Network DDM accord. to SFF-8472 (see Ethernet) | <ul style="list-style-type: none"> Link Status / Link Speed ONT Status / OLT Tx Power Optical Network Unit ID (ONU ID) Passive Optical Network ID (PON ID, Vendor + Equipment ID / Version) GPON Bridge/Router* | <ul style="list-style-type: none"> GPON Status Trace Serial Number / Password Configurable Scan PLOAM message (ONU ID, S/N)* SFP: Digital Diagnostic Mode (DDM) Optical Level (Rx), ±3 dB Optical Line Attenuation in dB |
| XGS-PON Tester | XGS-PON Modem Simulation, ONT, CPE ITU-T G.9807.1 via XGS-PON Transceiver <ul style="list-style-type: none"> 10 GigaBit Symmetric Passive Optical Network DDM accord. to SFF-8472 (see Ethernet) | <ul style="list-style-type: none"> Link Status / Link Speed ONT Status / OLT Tx Power Optical Network Unit ID (ONU ID) Passive Optical Network ID (PON ID, Vendor + Equipment ID / Version) XGS-PON Bridge/Router* | <ul style="list-style-type: none"> XGS-PON Status Trace Serial Number / Password Configurable Scan PLOAM message (ONU ID, S/N)* SFP: Digital Diagnostic Mode (DDM) Optical Level (Rx), ±3 dB Optical Line Attenuation in dB |
| Fiber Inspection Tool ext. Video Microscope | <ul style="list-style-type: none"> USB Microscope for the ARGUS optical Fiber Inspection manual Focusing with separate key optional: Autofocus digital Zoom | <ul style="list-style-type: none"> Pass /Fail evaluation according to IEC 61300-3-35 min. Particle Size 0.5 µm Defects: Core, Cladding, Adhesive, Contact | <ul style="list-style-type: none"> Scratches: Core, Cladding, Adhesive, Contact different Tips /Adapters included in scope of delivery PC, UPC, APC Single Mode /Multi Mode |
| VFL ext. Visual Fault Locator | <ul style="list-style-type: none"> Mini Visual Laser Source Output Power: 1 mW Detecting Range: about 5 km | <ul style="list-style-type: none"> Wavelength: 650 nm Laser Level: Class 2 Connector: Un/FC (optional) | <ul style="list-style-type: none"> Modulation Frequency: CW / 2 Hz Power Supply: 2 * AAA batteries |
| OLS ext. Optical Light Source | <ul style="list-style-type: none"> Wavelength: 1310 nm, 1490 nm, 1550 nm +1625 nm (± 20 nm) Stability: <ul style="list-style-type: none"> Short term (15 min): <ul style="list-style-type: none"> 1310 nm < ±0,05 dB 1490 nm < ±0,10 dB 1550 nm < ±0,05 dB 1625 nm < ±0,10 dB Long term (5 h): <ul style="list-style-type: none"> 1310 nm < ±0,10 dB 1490 nm < ±0,20 dB 1550 nm < ±0,10 dB 1625 nm < ±0,20 dB | <ul style="list-style-type: none"> Connector: SC/APC with dust protection and protection against loss Spectral width: 5 nm Frequency: 270 Hz, 1 KHz, 2 KHz Auto wavelength: protocol-based wavelength and TX power transmission Power: -5 dBm ±0.5 dB | <ul style="list-style-type: none"> Auto power off / backlight Power supply: 2x Ni-MH AA (2500 mAh), AC/DC charger Dimension (L x W x H): 160 x 76 x 45 mm Net weight: 270 g Accessories: AC/DC charger, 2 x AA battery, calibration report |

data sheet: technical data subject to change.

Further specifications:

| General: | | Application, Settings + Results: | |
|-------------------------------|--|---|---|
| GigE Tester | <p>Ethernet according to IEEE 802.3</p> <p>LAN:</p> <p>RJ45 interface (8P8C)</p> <ul style="list-style-type: none"> • 10/100/1000 Base-T • 2.5 GBase-T (IEEE 802.3bz, NBase-T) • 5/10 GBASE-T (5/10 GbE), 5000/10000 BASE-T, (MGBASE-T) (IEEE 802.3ak, IEEE 802.3an) <p>SFP: full-fledged SFP+ interface (FTTx, PtP)</p> <ul style="list-style-type: none"> • 100 Base-FX/LX (IEEE 802.3 Clause 26/58) • 1000 Base-BX/LX/SX/ZX Active Ethernet (IEEE 802.3 Clause 38 bzw. 802.3z) • 2,5 GBase-X (2,5GigE/2,5GbE) <p>10 GBASE-X (10GbE/10GE), 10000 BASE-X (IEEE 802.3ae)</p> | <ul style="list-style-type: none"> • Link Status, Autonegotiation, far/near • Auto-MDI(X) Function • Speed (10, 100, 1000, 2500, 10000 Mbit/s) • Duplex Mode (full, half) • Flow Control • Polarity/Wire Pair (+/-) • Pair skew/Wire Pair [ns] • Frames (Rx/Tx) [Number] • Errors, Bytes (Rx/Tx) [Number] • Collisions [Number] | <ul style="list-style-type: none"> • SFP: Digital Diagnostic Mode (DDM) <ul style="list-style-type: none"> - DDM nach SFF-8472 - Manufacturer Name, OUI, Item Number, Revision - Serial Number, Date, Coding, Medium, Speed - Optical Level (Tx/Rx), ±3 dB - Optical class of the OLT - Optical, PWR (Tx/Rx), ±3 dB - Temperature, Voltage, Current (Tx) - Max. Cable Length (Cu,SM,MM/OM1-4) |
| WLAN | <p>WLAN Access Point Mode</p> <p>WLAN Client Mode</p> <p>IEEE 802.11b/g/n (2.4 GHz)</p> <p>IEEE 802.11a/an/ac (5 GHz)*</p> <ul style="list-style-type: none"> • via WLAN USB Stick or • internal FPC Antenna • WEP to WPA2 Enterprise | <ul style="list-style-type: none"> • WLAN Access Point Scan <ul style="list-style-type: none"> - Number / List Access Points - Number 2.4 GHz / 5 GHz Networks - Network/Name (SSID) - Signal Strength (RSSI) [dBm] - Signal Quality [%] - MAC Address of AP - Used Channel/Frequency - Used Protocol - Negotiated Encryption - Authentication - Group Cipher, Pairwise Cipher | <ul style="list-style-type: none"> • Access Point Mode (WLAN Router) for mobile devices - IP Tests (Data, VoIP, IPTV) • AP Management (save etc.) • Test Result Upload via Web Server, WebDAV and FTP • Configuration Download via WebDAV and FTP • Remote Control via VNC, Web Server - Firmware Update via FTP Download |
| ARGUS® WLAN Analyzer | <ul style="list-style-type: none"> • Displaying the networks during existing WLAN connection • Manual evaluation of channels possible in tabular and graphical form | <ul style="list-style-type: none"> • Searching for networks again during existing WLAN connection | <ul style="list-style-type: none"> • Advanced automated evaluation of found networks and display of all AP info |
| WLAN spectrum analysis | <ul style="list-style-type: none"> • optional: ext. ARGUS® 2G4 Scope graph. WLAN spectrum analysis for 2.4 GHz for the specific WLAN troubleshooting | <ul style="list-style-type: none"> • Real-time Analysis /Graphics • passive (no WLAN Interference) • Channel Load • Graphical representation | <ul style="list-style-type: none"> • Detection of <ul style="list-style-type: none"> - Bluetooth Devices - Motion Sensors - Microwave Ovens - Baby Phones |

data sheet: technical data subject to change.

Specifications Protocol and IP tests (Triple Play):

| General: | Applications, Settings + Results: | |
|-------------------------------------|---|---|
| Protocol Tests | <ul style="list-style-type: none"> Configurable MAC Address Use of Virtual Lines (VL): Maximum Flexibility as well as Control and Priorization under Real Conditions by Several VLs simultaneously One VL/Service each (Data, VoIP, IPTV, opt.) VL Configurable in Profiles (20) <ul style="list-style-type: none"> IP, PPPoE VLAN (Modus, ID, Prio., TPID) PPP Profiles (Username, Password) IP Version (IPv4, IPv6, Dual) + DHCP Automatic receiving of connection-dependent dial-in data: PPP, VoIP (phone number) | <ul style="list-style-type: none"> Display of BRAS Information <ul style="list-style-type: none"> AC Name, Service Name, Session ID Display of PPP Information <ul style="list-style-type: none"> PPP Packets/Bytes (Tx/Rx) PPP Trace (PPP Commands, Time) Display of IP Information <ul style="list-style-type: none"> IPv6: Global Unicast/Link Local Address IPv4: Assigned IP, Gateway, DNS Recording of a Data Log for Evaluation on PC (e.g. Wireshark) |
| Data Tests (Download Tester) | <ul style="list-style-type: none"> Memory with up to 10 IP Addresses, (IPv4/6 Address as Number or Name) Number of Pings, Pause Configurable (Ping), Packet Size + Fragmentation Configurable Traceroute: Max. Hops, Probes + Timeout Conf. Down-/Upload: Server Profiles (10): Server Addr., File Name/Size, Number, Number of Parallel Downloads Configurable <ul style="list-style-type: none"> FTP: Username + Password Display Results IP Ping <ul style="list-style-type: none"> Display of Packets (Tx/Rx/repeated) Checksum Error [Number] Error Packets [Number] Display Results Traceroute <ul style="list-style-type: none"> Current Hop + Probe / List of Hops Response Time of Hops [s] IP Address of Current Hops | <ul style="list-style-type: none"> Round Trip Time (min/max/avg) [ms] Display Results Down-/Upload <ul style="list-style-type: none"> Current/Total Number [Number] Already Loaded Data [%] Average Speed [Mbit/s] Loaded Bytes [MB] Transfer Time /Remaining Time [h:min:s] ARGUS® Real Speed Direct (iperf) <ul style="list-style-type: none"> Client /Server Mode TCP Throughput Down-/Upload ARGUS® against ARGUS® ARGUS® Real Speed Formal (RFC6349) <ul style="list-style-type: none"> Throughput Test Evaluation TCP Throughput according to RFC 6349 |
| VoIP Tests (VoIP Tester) | <ul style="list-style-type: none"> Configuration in VoIP Profiles (20): SIP Username, Password, Registrar Server, Outbound Proxy/SBC, Domain, Listen + Remote Port, Authentication, Caller ID, User Agent, Qualify, Process of Registration Phone Settings: RTP Port Area, Silence Detection, Jitterbuffer, Codecs, DTMF STUN Server MOS Threshold for OK/Fail Evaluation VoIP QoS, Layer 3 Diffserv: RTP/SIP: ToS, DSCP VoIP QoS, Layer 2 VLAN Prio.: RTP/SIP: VLAN Prio. Codecs: G.726 (16/24/32/40), G.729 (A/B), G.711 (a-law/μ-law), G.722 Display of Own Number, Number of Called Person | <ul style="list-style-type: none"> Duration of Connection [h:min:s] MOS Plain Text Evaluation, According to E Model R Factor, ITU-T G. 107 (current/avg), MOS (current/avg/min/max/ideal) Statistics: RTP Packets (Tx/Rx), Error Counter: RTP Drop, RTP Error RTP Jitter Rx (current/avg/min/max) Lost RTP Packets (avg/min/max) RTCP Contents: <ul style="list-style-type: none"> RTP Jitter far (current/avg/min/max) [ms] Lost RTP Packets of Remote Side Network Delay (current/avg/min/max) [ms] Display of Registration Details: SIP Codes, Registrar IP, Proxy, URI Simulation (VoIP NT) |

data sheet: technical data subject to change.

| General: | Applications, Settings + Results: | |
|--|---|--|
| IPTV Tests (IPTV Tester) IPTV Device Simulation IPTV STB Simulation (Set-top Box) OK/Fail Evaluation IPTV Channel Scan IPTV Monitor (IPTV passive) | <ul style="list-style-type: none"> • Configuration in IPTV Profiles (3): Editable Channel List (up to 250 Channels), Multicast IP + Port, Channel Name, IGMP version • Thresholds for IPTV OK/Fail-Evaluation: IGMP Latency, Sync Error, PCR Jitter, Error Indication, CC Errors, CC Error Rate, Audio + Video Bytes, RTP Jitter, RTP Sequence Error, Current + Total RTP Loss Rate • Different VLs for IGMP + RTP • Scan Profiles (3) Configurable: max. Zapping Time • Display of Selected IPTV Channel, Test Duration, current Bitrate, OK or Fail • Packets Loss (current/min/max/avg) [Number] | <ul style="list-style-type: none"> • RTP/UDP Packet Loss Rate [%] • Delay [ms] + Delay Factor [ms] • Media Loss Rate (MLR) [%] • IP Address of Channel + Port • IGMP Latency (Activation Time) [ms] • For Correlation: xDSL CRC Counters • RTP Errors, RTP Sequence Errors • MPEG Bitrate + Packets (min/max/...), Bytes (current/min/max/...), PCR Jitter (current/min/max/avg) [ms], CC Errors + Error Rate (current/max) [%], Error Sync + Indication • Codecs and PIDs (Packet Identifier) • Channel Zapping Time (min/max/avg) [ms] |

data sheet: technical data subject to change.

| Documentation and Analysis | |
|---|--|
| • Documentation of all parameters recorded to test reports (in device and on PC) via automatic access tests | |
| • Transfer of test results via QR code to a smartphone or via WLAN to cloud (FTP server) | |
| • Free of charge firmware updates via cloud or ARGUS update tool (www.argus.info) | |
| • WLAN for transf. test results to systems of an electronic order processing system, access point mode (browsing, download), remote control via smartphone | |

| Device Specifications | |
|---|---|
| Technical Features: | |
| • Power | Li-Ion battery pack or plug-in mains adapter |
| • Power management | User configurable |
| • Keypad | 8 keys, 4 cursor keys |
| • TFT colour display | 800 x 480 pixels, backlit, incl. touchscreen |
| • 3 LEDs | Indicating the status + Ethernet port LEDs |
| • Handset | Integrated earpiece and microphone |
| • ARGUSpedia | Integrated help function |
| • CE marking | Complies with CE directives |
| • User safety | Fulfills EN 60950-1:2006-11 |
| • RoHS conformance | Conformance according to WEEE directive |
| Interfaces: | |
| • USB client interface, 2x USB host interface | Type US-C (power), Type A |
| • WLAN | IEEE802.11a/b/g/n |
| Environmental conditions: | |
| • Temperature range for charging battery pack | 0 °C (+32 °F) up to +40 °C (+104 °F) |
| • Max. Operating temperature (endurance tests) | 0 °C (+32 °F) up to +40 °C (+104 °F) |
| • Max. Operating temperature (in battery mode) | -10 °C (+14 °F) up to +50 °C (+122 °F) |
| • Operating temperature (with power/car adapter) | 0 °C (+32 °F) up to +40 °C (+104 °F) |
| • Storing Temperature | -20 °C (-4 °F) up to +60 °C (+140 °F) |
| • Relative humidity | Up to 95 %, non-condensing |
| Dimensions: | |
| • Size | H x W x D: 272 x 128 x 79 mm (10.71 x 5.04 x 3.11 in) |
| • Weight | approx. 1200 g (2.65 lbs) ARGUS incl. battery pack |

data sheet: technical data subject to change.

| Standard Package: | | |
|--|---|----------------------|
| Basic device incl. Selective xPON OPM, PON ID, Wi-Fi-Management, IP tests (IP ping, traceroute test, HTTP/FTP download, FTP upload/server), Web browser, Cloud services, Lithium-Ion battery pack, Mains adaptor, Shock absorbing rubber jacket, Carrying case, SC/LC measuring cable, Carrying strap, Hand strap and English manual | | |
| Additional Options: | | |
| • PON installation test | w/o stick | Order number: 024610 |
| • GPON-ONT for xPON-OPM | incl. GPON Transceiver SFP | Order number: 024602 |
| • XGS-PON-ONT for xPON-OPM | incl. XGS-PON Transceiver SFP | Order number: 024603 |
| • xPON 5x OPM | incl. Through Mode + Up/Downstream level measurement | Order number: 024604 |
| • Optical Light Source (OLS) | | Order number: 000280 |
| • Fiber Inspection option | w/o Fiber Inspection Tool | Order number: 024694 |
| • Wi-Fi Test Interface | w/o Wi-Fi USB stick (000250) | Order number: 024659 |
| • ARGUS® WLAN Analyzer | requires WLAN basic | Order number: 024654 |
| • ARGUS® 2G4 Scope (2.4 GHz Spectrum Analysis) | incl. USB 2G4 Scope stick | Order number: 000240 |
| • VoIP Option | incl. MOS value, Call generator, NT Sim., SIP trunk | Order number: 024660 |
| • IPTV Option | incl. IPTV STB mode, IPTV passive, channel scan | Order number: 024665 |
| • Triple Play package | incl. VoIP and IPTV Option | Order number: 024667 |
| • ARGUS® Real Speed Formal (6349) | incl. ARGUS® Real Speed Direct (iperf), requires Art. No. 024605 | Order number: 024656 |
| • Speedtest up to 2.5 Gbit/s | via Ethernet (LAN4, SFP4) + fiber via transceiver SFP incl. ARGUS® Real Speed Direct (iperf); requires Art. No. 024604 | Order number: 024605 |
| • Speedtest up to 10 Gbit/s | via Ethernet (LAN4, SFP4) + fiber via transceiver SFP incl. ARGUS® Real Speed Direct (iperf); incl. Ethernet Cat6 Patch Cable 1:1 (red); requires Art. No. 024604 | Order number: 024606 |
| * We would be glad to provide further details and information about additional accessories on request. | | |

data sheet: technical data subject to change.



GESELLSCHAFT FÜR
INFORMATIONSTECHNIK mbH

Rahmedestraße 90
D-58507 Lüdenscheid

Tel: +49 2351 9070-0

Fax: +49 2351 9070-70

E-Mail: sales@argus.info

Internet: www.argus.info/en / www.fibertester.de

 www.instagram.com/intec_argus

 www.facebook.com/intec.argus

 ARGUS testing the telecom network

 <https://www.linkedin.com/company/441568>